

QUICK START GUIDE DX4

DX4-1A5A ... DX4-130A





SAFETY WARNING

During the installation or use of control systems, users of Trio Motion Technology ® products must ensure that there is no possibility of injury to any person or damage to machinery.

Control systems, especially during installation, can malfunction or behave unexpectedly. Bearing this in mind, users must ensure that even in the event of a malfunction or unexpected behaviour, the safety of personnel is never compromised.

Only qualified specialist staff, personnel with expertise in the installation, assembly, commissioning and operation of electro-mechanical equipment are permitted to perform the above tasks.

The qualified personnel must know and observe the corresponding national accident and prevention regulations, as well as observe these instructions and the supportive manual. Similarly, all personnel who work with this equipment must be suitably trained on the contents of these instructions and the supportive manual.

The manufacturer of the machine must generate a risk assessment and take appropriate measures to ensure that unforeseen movements or incidents cannot cause injury or damage to any person or property, guidance in the generation of the risk assessment can be obtained in ISO 12100, Safety of machinery – General principles for design – Risk assessment and risk reduction.

Pay close attention to all technical data and the specifications on connection conditions. If permissive voltages values or current values are exceeded, the device can be damaged. Unsuitable motor or wrong wiring will damage the system components. Check the combination of drive and motor, ensuring the compatibility of the rated voltage and current of the units.



DANGER

1. Never remove covers, cables, connectors, or optional devices while power is being supplied to the Drive.
2. Wait for five minutes after turning the power supply off and then make sure that the CHARGE indicator is not lit before starting wiring or inspection work.
3. Never touch the power supply terminals after turning off the power supply while the CHARGE lamp is lit, because high voltages may still be present in the Drive.

WARNING

1. Use a power supply that is appropriate for the product, check number of phases, voltage, frequency, and AC/DC type.
2. Connect the ground terminals on the Drive and Motor to ground poles according to local electrical codes.
3. Never damage, pull on, apply excessive force to, place heavy objects on, or pinch cables.
4. Never attempt to disassemble, repair, or modify the product.
5. Make sure that the device in an emergency stop state at any time when the product has been connected to the machine and ready for the operation.
6. Never touch inside the Drive.

CAUTION

1. The Drive heat sinks, regenerative resistors, Motor, and other components can be very hot while power is ON or soon after the power is turned off. Implement safety measures, such as installing covers, so that hands and parts such as cables do not come into contact with hot components.
2. For the control power supply, use a power supply device with double insulation or reinforced insulation.
3. Never use the product in an environment that is subject to water, corrosive gases, or flammable gases, or near flammable materials.
4. Never attempt to use a Drive or Motor that is damaged or that has missing parts.
5. Install external emergency stop circuits that shut off the power supply and stops operation immediately when an error occurs.
6. In locations with poor power supply conditions, install the necessary protective devices (such as AC reactors) to ensure that the input power is supplied within the specified voltage range.
7. Always use a Noise Filter to minimize the effects of electromagnetic interference.
8. Always use a Motor and Drive in one of the specified combinations.
9. Never touch a Drive or Motor with wet hands.





CONNECTIONS

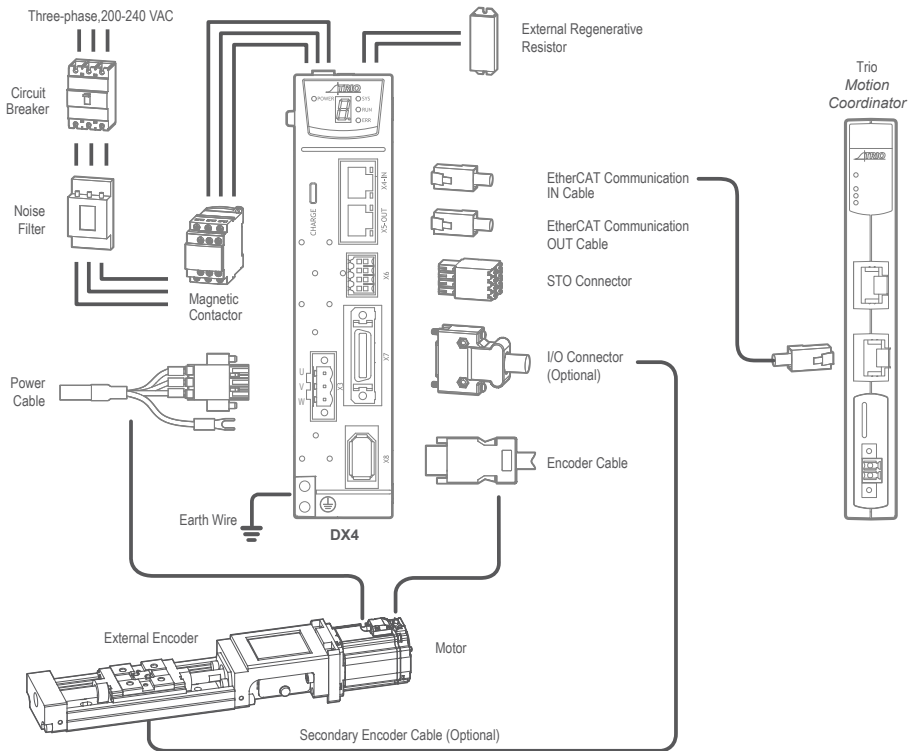



POWER SUPPLY CONNECTOR WIRING

Prepare the following items before preparing the wiring for the Main Circuit Terminals and Control Circuit Terminals.

You will require:

Flat-blade screwdriver:	with tip width of 3.0mm to 3.5mm
Cold pressed terminals:	Sleeve type ferrule with cross-section from 1.5mm ² to 2.5mm ² and a length of 10mm
Wiring pliers:	Commercially available pliers with crimping and stripping functions

Follow the procedure below to wire the Main Circuit Terminals and Control Circuit Terminals.

1. Remove the Main Circuit Terminals and Control Circuit Terminals from the Drive.
2. Peel off the sheath of the wire so that the conductor portion of the cable will protrude from the tip of the ferrule.
3. Insert the cable into the ferrule (It should protrude 1mm or more from the ferrule).
4. Crimp the cable that has been inserted into the ferrule and cut off the cable conductor portion protruding from the ferrule (The allowable protruding length after cutting should not be more than 0.5mm).
5. Insert the crimped cable into the connection terminals directly until the cable is not easily pulled out (A slight pull is allowed). *Figure 1*.
6. Make all other connections in the same way.
7. To remove the wiring, pull the cable out of the connection terminals.
8. Use the flat-blade screwdriver to press down the spring button corresponding to the terminal, and then gently pull out the cable. *Figure 2*.
9. Once the wiring is completed, attach connection terminals to the Drive.

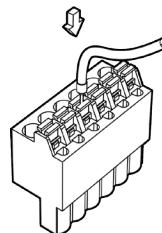

Figure 1

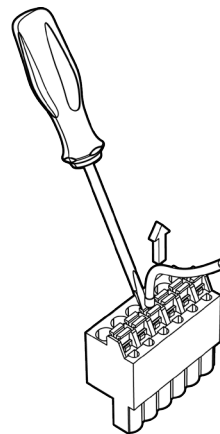

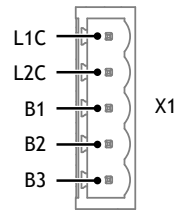

Figure 2



POWER SUPPLY CONNECTORS (X1, X2)

Symbols	Name	Specifications and Reference
L1C, L2C	Control power supply terminals	Single-phase, 200V ac to 240V ac, -15% to +10%, 50Hz or 60Hz
B1, B2, B3	Regenerative Resistor terminal	There is a factory fit short between B2 and B3. When the busbar capacitance is insufficient, remove the short wiring, and connect an external regenerative resistor between B1 and B2.
	Ground terminal	Always connect this terminal to prevent electric shock.



POWER SUPPLY CONNECTORS (X2)

Symbols	Name	Specifications and Reference
L1, L2, L3	Main circuit power supply input terminals	Three-phase, 200V ac to 240 V ac, -15% to +10%, 50Hz or 60Hz
P1, P2, N	DC terminals	There is a factory fit short between P1 and P2. For using a DC reactor, remove the short wiring, and connect a DC reactor between P1 and P2. For using a DC power supply, connects P2 to the positive pole, and connects N to negative pole. For the common DC bus, connect all P2 of Drive to the positive pole, and N to the negative pole.
	Ground terminal	Always connect this terminal to prevent electric shock.

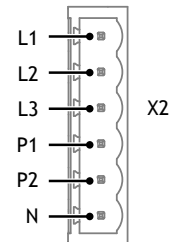



MOTOR POWER CONNECTOR (X3)

Pin	Symbol	Colour
1	U	Brown
2	V	Gray
3	W	Black

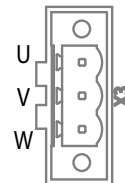

RJ45 ETHERNET CONNECTOR (X4 AND X5)

EtherCAT communication (X4-IN and X5-OUT) are RJ45 terminals. The communication cable from the network master or controller should be connected to X4-IN and X5-OUT should be connected to the X4-IN terminal of the next Drive (or network device)

Pin	Signal	Description
1	TX+	Send data +
2	TX-	Send data -
3	RX+	Receive data +
4	N/C	N/C
5	N/C	N/C
6	RX-	Receive data -
7	N/C	N/C
8	N/C	N/C
Shell	PE	Protecting earthing (shield)

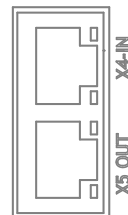

Use category 5 (CAT5e SF/UTP) Ethernet communications cables for network connections. Metal shielded connectors are recommended to prevent signal interference.



STO FUNCTION SIGNALS (X6)

This product has the integrated safety function Safe Torque Off (STO) according to IEC 61800-5-2, which is equivalent to an uncontrolled stop in accordance with stop category 0 of IEC 60204-1, which can protect people from dangerous movements of the machine and reduce the risk to the operator.

The Safe Torque Off (STO) function is a safety function that shuts the Motor current and turns off Motor output torque by turning off the driving signal of the Drive's internal power transistor when safety input signal is detected.

However, the safety function STO is not equivalent to the safety function safe off of IEC 60204-1, since it does not provide any galvanic insulation. This means that the Motor terminals can still have dangerous voltage when in STO state.

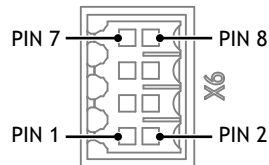

PLEASE USE THE PELV/SELV SWITCHING POWER SUPPLYING TO THE IO SIGNAL OF THE STO FUNCTION. THE EXTERNAL SIGNAL SHALL MEET THE IDLE-CURRENT PRINCIPLE.

Pin	Signal	Name	Function
1	0 V	24 V Power Supply	(Do not use these pins because they are connected to internal circuits)
2	24 V		
3	HWBB1-	HWBB1 Input	The STO function takes effect when the HWBB1 or the HWBB2 signals is turned OFF.
4	HWBB1+		
5	HWBB2-	HWBB2 Input	
6	HWBB2+		
7	EDM-	External Device Monitor Output	Turns ON when the HWBB1 signal or the HWBB2 signal is turned OFF.
8	EDM+		



Please refer to the User Manual for more information.



I/O CONNECTOR (X7)

Pin	Name	Type	Function
1	TP1+	Input	Touch Probe Input 1
2	TP1-	Input	
3	TP2+	Input	Touch Probe Input 2
4	TP2-	Input	
5	DIN_COM	Input	Power supply to DIN signals, connect to a 24V dc power supply or 0V.
6	DOUT0+	Output	General purpose digital output 0.
7	DOUT0-	Output	
8	DOUT1+	Output	General purpose digital output 1.
9	DOUT1-	Output	
10	DOUT2+	Output	General purpose digital output 2.
11	DOUT2-	Output	
12	DOUT3+	Output	General purpose digital output 3.
13	DOUT3-	Output	
14	DIN0	Input	General purpose digital input 0.
15	DIN1	Input	General purpose digital input 1.
16	DIN2	Input	General purpose digital input 2.
17	DIN3	Input	General purpose digital input 3.
18	DIN4	Input	General purpose digital input 4.
19	PIA+	Output	Second Encoder Input, channel A.
20	PIA-	Output	
21	PIB+	Output	Second Encoder Input, channel B.
22	PIB-	Output	
23	PIC+	Output	Second Encoder Input, channel C (index pulse).
24	PIC-	Output	
25	0V	Output	Supply voltage for second encoder.
26	+5V	Output	

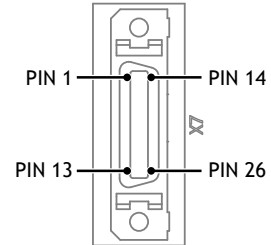



ENCODER PORT (X8)

Pin	Symbols	Color
1	PG5V	Red
2	PG0V	Black
3	N/C	N/C
4	N/C	N/C
5	MA+	Green
6	MA-	Green-Black
7	S+	Blue
8	S-	Blue-Black
9	BAT+	Yellow
10	BAT-	Yellow-Black
Shell	FG	Frame ground

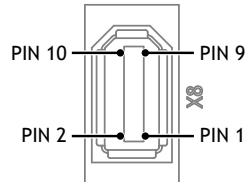

ENCODER BATTERY CONNECTION

Absolute encoders are fitted on motors with an encoder type of L. These encoders require a battery supply to retain the absolute encoder data when the Drive power is removed.

This battery supply is provided by an in-line battery fitted into a battery box in the cable which allows the encoder supply to be retained when the Encoder Cable is removed from the Drive.



To retain absolute encoder data, ensure that the Control power supply to the Drive is ON when the battery supply is removed.



DISPLAY

The Status indicators on the Drive show the status of the EtherCAT network and the servo control.

The **POWER LED** indicates power is present to the Control board.

The **CHARGE LED** indicates the voltage level on the Main circuit.

The seven-segment display shows the status of the motor control.

The LEDs labelled **SYS**, **RUN** and **ERR** along with the LEDs integrated into the RJ45 connectors are the network status indicators.

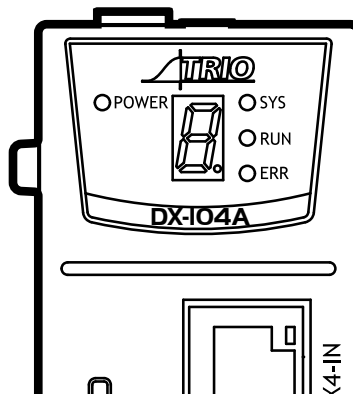



MOUNTING DIMENSIONS (LOOKING FROM FRONT)

The Drives are based mounted and should be fitted to a non-painted metal surface. Mount the Drive vertically, as is shown below.

Mount the Drives so that the Display Panel is facing toward the operator. Prepare two or three mounting holes for the Drive and mount it securely in the mounting holes (The number of mounting holes depends on the size of the Drive).

The DX4 can be mounted so that the distance between adjacent Drives is 1mm.

Use all mounting holes to securely mount the Drive to the mounting surface.

To mount the Drive, use a screwdriver that is longer than the depth of the Drive

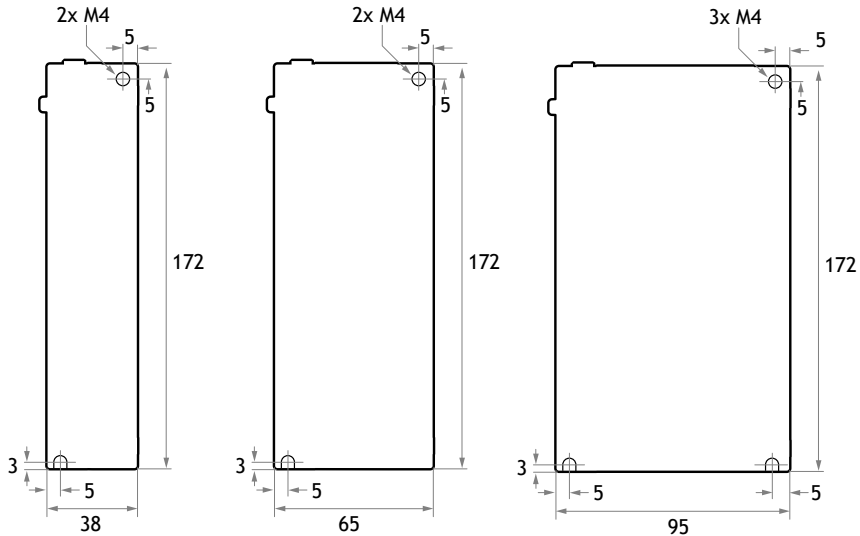

ENSURE THAT THE VENTILATION SLOTS AT THE TOP AND BOTTOM OF THE DX4 ARE KEPT CLEAR TO ENSURE A FREE FLOW OF AIR THROUGH THE MODULE.



INSTALLING DRIVE(S) IN A CONTROL CABINET

When installing a drive or drives, use the image below as a reference for free space around the installation.

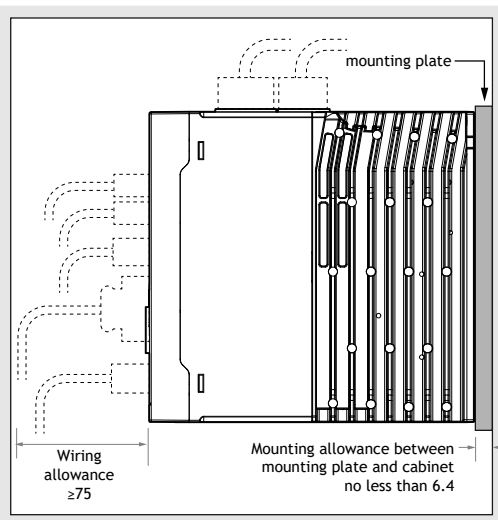
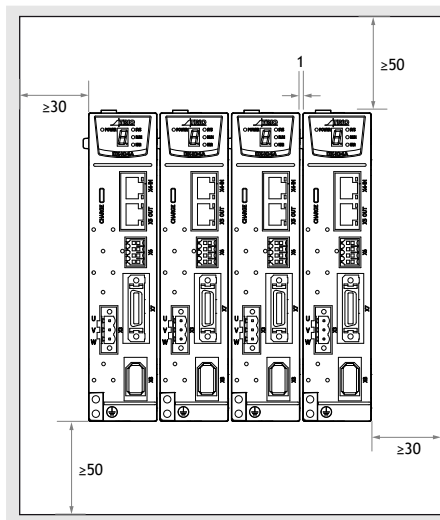



OVERALL DIMENSIONS DX4-120

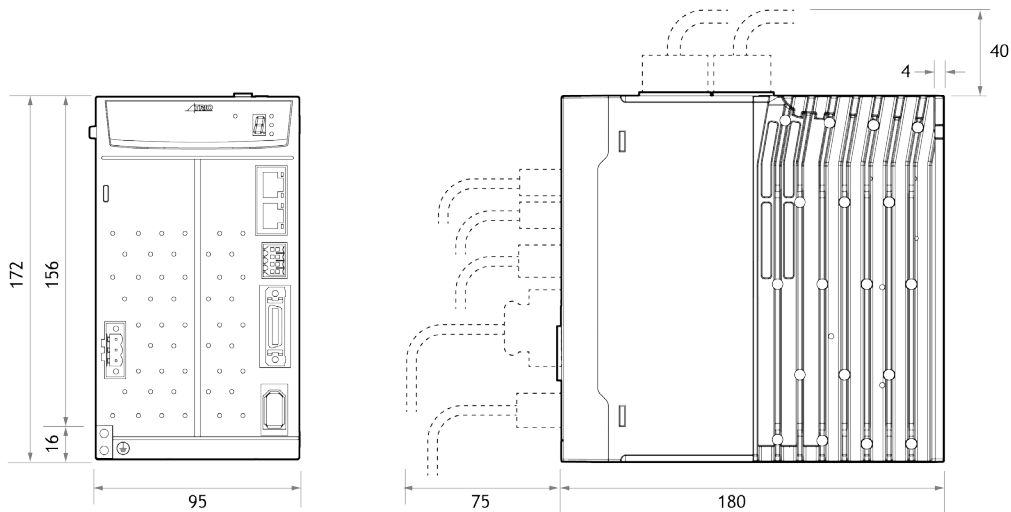



OVERALL DIMENSIONS DX4-108

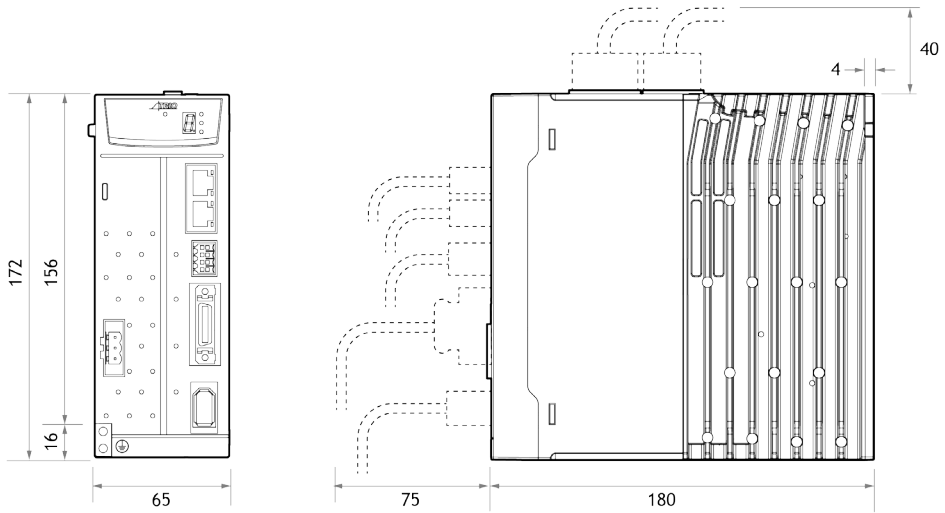



OVERALL DIMENSIONS DX4-104

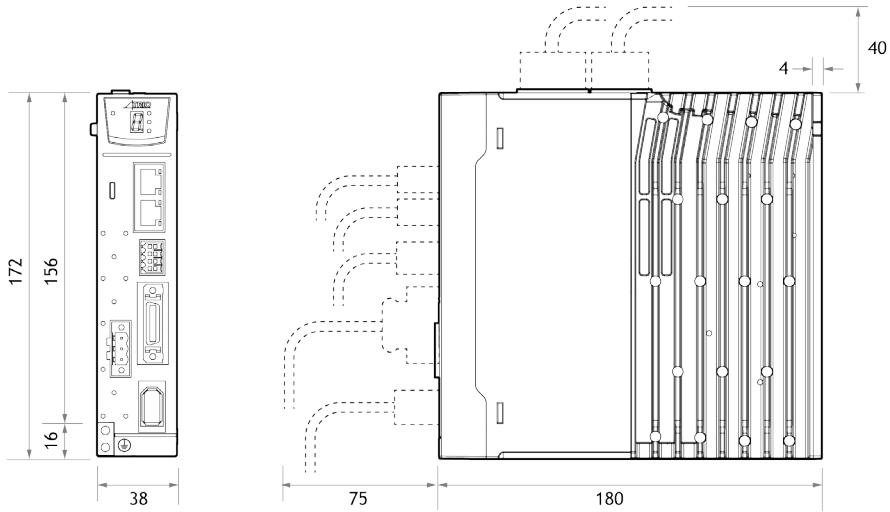

UK | USA | CHINA | INDIA
WWW.TRIOMOTION.COM
THE MOTION SPECIALIST

CAD data Drawings to aid packaging and mounting are available in various formats from the Trio web site. Products should be wired by qualified persons.
Specifications may change without notice. E & OE

Quick Start v2 February 2021

